

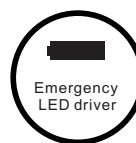

HONGYAO Lighting

Specification Sheet

- LED WRAPAROUND -

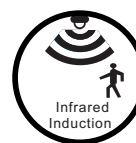

Zhejiang Hongyao Lighting Electrical Co., Ltd

No.209 Shennan Rd. Da Yang Jie Dao, Linhai City. Zhejiang China 317000 www.chongyao.com
Trading@chongyao.com Tel: +86 576-85381918 Fax:+86 576-85381913



SPECIFICATIONS

FEATURE

- High energy efficiency: 40W replace 2x32W T8
- Suitable for damp location
- Steel housing
- Equipped with heat resistant prismatic lens
- Acrylic lens available in 4' and 8' length
- Chain or surface mount installation
- Option: available with emergency backup kit/motion sensor
- One piece 8' lens



APPLICATION

- Commercial; Industrial; Warehouse; Retails; Residential garage; school/institution; supermarket...

Specifications

Specifications		
Model No.	HY -4FT-LW102-40W-XXK	HY -8FT-LW102-80W-XXK
Power:	40W	80W
Size:	4ft	8ft
Input Voltage:	120-277 VAC	
Dimming	0-10V Dimmable	
Lumens	5200LM	10400LM
Protection Rating	IP20 (For Indoor Use Only)	
Power Factor:	>0.9	
Beam Angle	120°	
CCT:	3000K/4000K/5000K	
CRI:	>80	
Working Life:	Lumen Maintenance over 70% @ 50,000+ Hours	
Oper. Temperature	-13°F ~+113°F / -25°C ~+45°C	
Certification	DLC Premium / ETL	

Zhejiang Hongyao Lighting Electrical Co., Ltd

No.209 Shennan Rd. Da Yang Jie Dao, Linhai City. Zhejiang China 317000 www.chongyao.com
 Trading@chongyao.com Tel: +86 576-85381918 Fax:+86 576-85381913

PRODUCT DIMENSIONS

8ft Front View

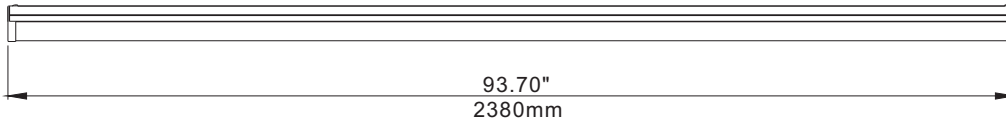

Side View

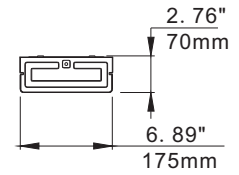

4ft Front View

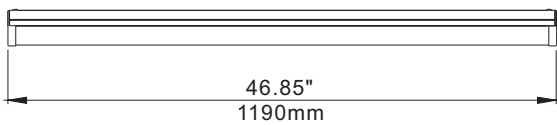

Side View

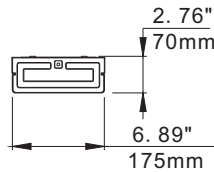

PHOTOMETRIC REPORT

4ft LED WRAP

LUMINOUS INTENSITY DISTRIBUTION DIAGRAM

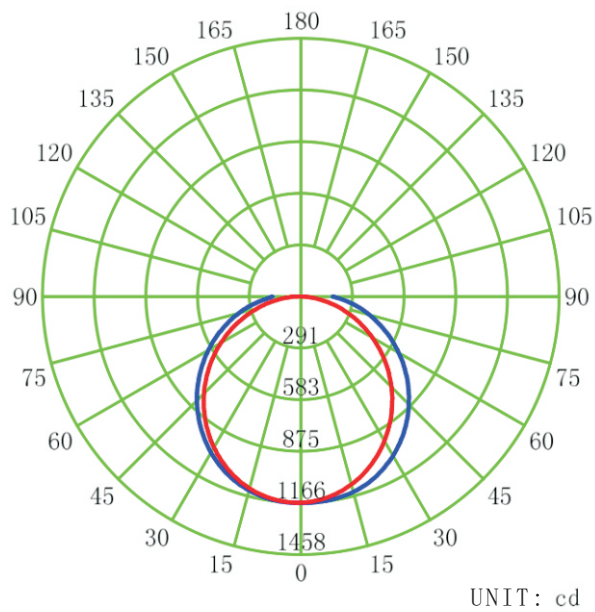

— C0-C180 — C90-C270

VERTICAL EQUILUMINOUS CURVE

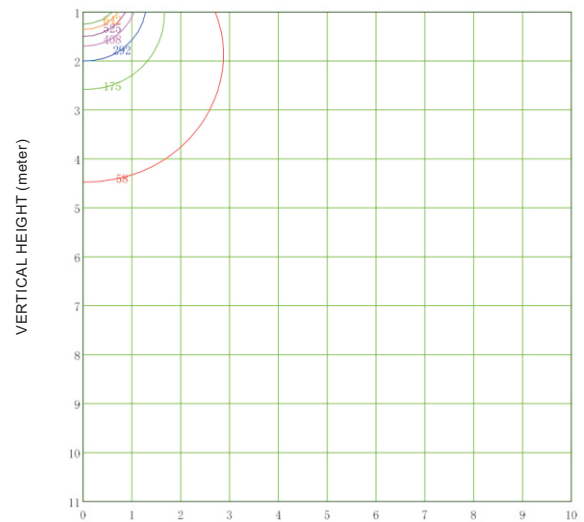

HORIZONTAL DISTANCE (meter)

MINIMUM ALTITUDE 1.0 M
MAXIMUM ALTITUDE 11.0 M
MAXIMUM ILLUMINATION 1166.9 lx

- (5%): 58.3 lx
- (15%): 175.0 lx
- (25%): 291.7 lx
- (35%): 408.4 lx
- (45%): 525.1 lx
- (55%): 641.8 lx
- (65%): 758.5 lx



ORDERING GUIDE

Package Information		
Model No.	HY -4FT-LW102-40W-XXK	HY -8FT-LW102-80W-XXK
Size	4ft	8ft
Qty/Pack	5 PCS	3 PCS
Package Size	1230X455X215mm 48.43"X17.91"X8.47"	2410X280X240mm 94.9"X11.02"X9.45"
Package Weight	17.5kg/38.58 lbs	21.2kg/46.74 lbs
Package CBM	0.120325	0.161952
40GP Capacity	~2410 PCS	~1070 PCS
40HQ Capacity	~2820 PCS	~1250 PCS
45HQ Capacity	~3240 PCS	~1440 PCS

ORDERING CODE DEFINITION

Company Code	Size	Product	Watt	XXK
HY	4ft 8ft	LW102: LED Wrap	4ft:40W 8ft:80W	3000K 4000K 5000K CCT Selectable

WARNING

- This product must be installed in accordance with the applicable installation code by a person familiar with the construction and operation of the product and hazards involved
- Risk of fire or electric shock. LED lamp installation requires knowledge of luminaries electrical systems. If not qualified, do not attempt installation. Contact a qualified electrician.
- Use in dry locations only.
- This lamp supports dimming function, must use with dimmers.
- Small noises when shaking does not affect the quality.



INSTALLATION INSTRUCTION

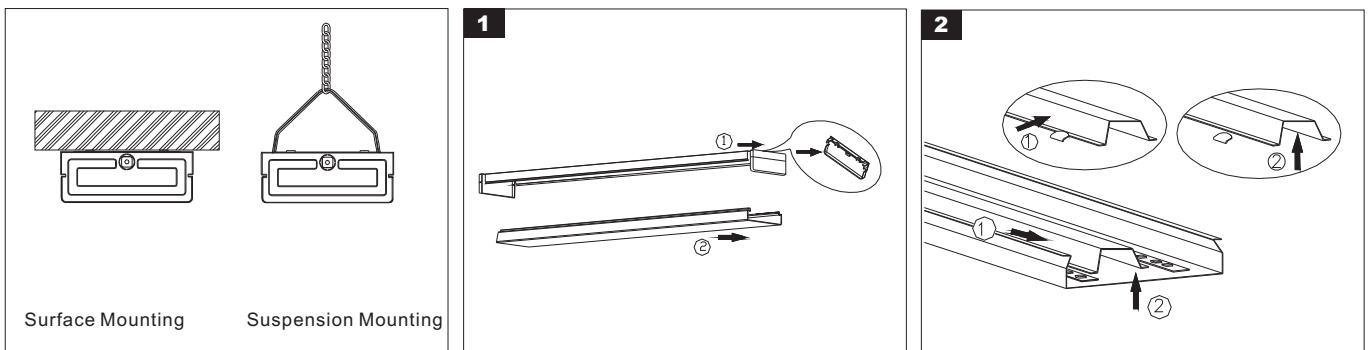

INSTALLATION INSTRUCTION

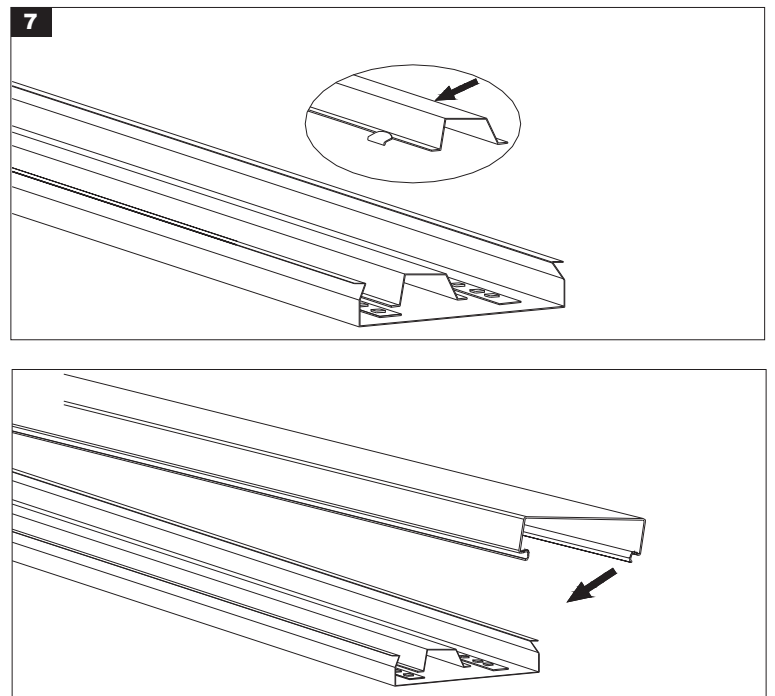
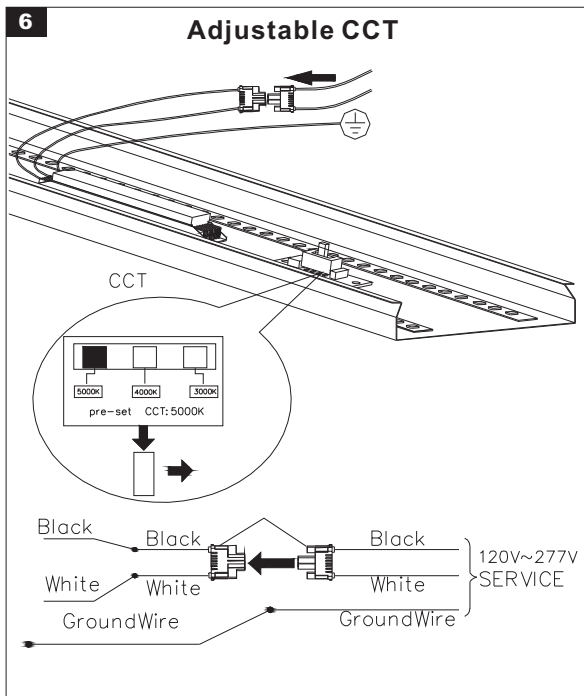
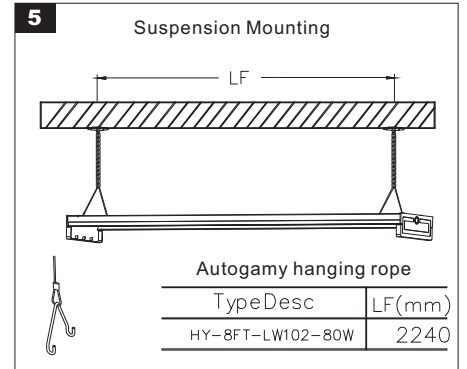
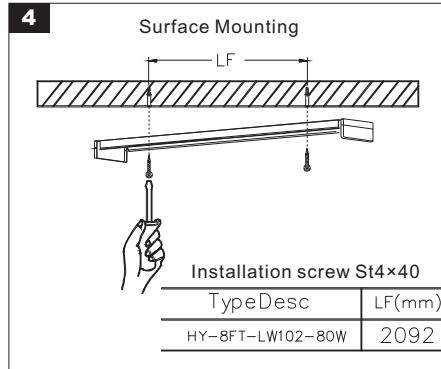
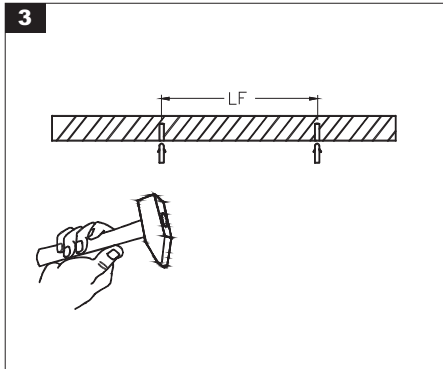

Wiring Guide

